

1 Features and Benefits

- Small size single die, low cost 16x4 pixels IR array
- Easy to integrate
- Industry standard four lead TO-39 package
- Factory calibrated. Pixel to pixel relative error below 1.5%
- NETD (Noise Equivalent Temperature Difference) 0.2K@4Hz refresh rate
- I²C compatible digital interface
- Programmable refresh rate 0.5Hz...512Hz (averaging recommend frame rate 32Hz)
- 2.6V typical supply voltage
- Current consumption less than 9mA
- Sleep mode consumption less than 5µA
- Measurement start trigger for synchronization with external control unit
- Different package options for applications and measurements versatility
- Ta -40 to 85 °C
- To -50 to 1100 °C possible; depending on accuracy requirement

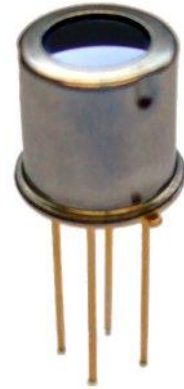

2 General Description

The HTPA 16x4 is a (16x4 pixels) fully calibrated IR array in industry standard four lead TO-39 package. It contains 2 chips in one package: the HTPA 16x4 (IR array plus electronics) and the 24AA02 (256x8 EEPROM)

The HTPA 16x4 contains 64 IR pixels with dedicated low noise chopper stabilized amplifier and fast ADC integrated. A PTAT (Proportional To Absolute Temperature) sensor is integrated to measure the ambient temperature of the chip. The outputs of both IR and PTAT sensors are stored in internal RAM and are accessible through I²C.

The results of the infrared sensor measurements are stored in RAM:

- 16-bit result of IR measurement for each individual sensor (64 words)
- 16-bit result of PTAT sensor

Depending on the application, an external microcontroller can read the different RAM data and, based on the calibration constants, compensate the different sensitivities of each pixel to build up a thermal image, or calculate the object temperature at each pixel at the imaged scene.

These constants are accessible by the microcontroller through the I²C bus and have to be used for external post processing of the thermal data. This post processing includes:

- Ta calculation
- Pixel offset cancelling
- Pixel to pixel sensitivity difference compensation
- Object emissivity compensation
- Object temperature calculation
- Image processing and correction if necessary

The result is an image with NETD better than 0.5K at 1Hz refresh rate.

The refresh rate of the array is programmable by means of EEPROM settings or directly via I²C command. Changes of the refresh rate have a direct impact on the integration time and noise bandwidth (faster refresh rate means higher noise level). The refresh rate is programmable in the range 0,5Hz...512Hz and can be changed to achieve the desired tradeoff between speed and accuracy.

The HTPA 16x4 requires a single 3V supply ($\pm 0,4V$).

The customer can choose between 3 operating modes:

- **Normal.** In this mode the device is free running under control of the internal state machine. Depending on the selected refresh rate Fps (Frame per second) the chip is constantly measuring both IR and PTAT and is refreshing the data in the RAM with specified refresh rate;
- **Step.** This mode is foreseen for synchronization with an external micro-controller. The internal state machine is halted. If the command 'StartMeas' is received via the I²C bus, a single measurement of all IR and PTAT sensors will be done, then the chip will return in wait state. When in wait state the data in RAM can be read.
- **Power saving mode.** In this mode all internal electronics will be completely shutdown and the chip will monitor the I²C. Any transmission through I²C initiated by Start condition will be detected. The internal oscillator will be powered on and the device will receive the slave address (SA). If the SA address of HTPA 16x4 is recognized (SA=0x60) the device will respond, receive and execute the command. Otherwise the chip will remain in power saving mode. The power saving mode can reduce current consumption down to 5 μ A and is excellent for battery applications.

The HTPA 16x4 is factory calibrated in wide temperature ranges:

- -40...85 °C for the ambient temperature sensor

- -70...300 °C for the object temperature (up to 1100°C possible, depending on accuracy requirement).

All figures are depending on the accuracy requirement.

Each pixel of the array will measure the average temperature of all objects in its own Field Of View (called FOV).

It is very important for the application designer to understand that the accuracy of the temperature measurement is very sensitive to the thermal equilibrium isothermal conditions (there are no temperature differences across the sensor package). The accuracy of the thermometer can be influenced by temperature differences in the package induced by causes like (among others): Hot electronics behind the sensor, heaters/coolers behind or beside the sensor or by a hot/cold object very close to the sensor that not only heats the sensing element in the thermometer but also the thermometer package.

This effect is especially relevant for thermometers with a small FOV as the energy received by the sensor from the object is reduced. Therefore, Heimann Sensor has integrated the possibility to measure the internal thermal gradients and to compensate the temperature calculation for them. However, this cannot completely compensate the effect of thermal gradients. It is therefore important to avoid the causes of thermal gradients as much as possible or to shield the sensor from them.

Directory

1	Features and Benefits	1
2	General Description	2
3	Ordering Information	6
4	Pin Configuration	6
5	Dimensional Drawings	7
6	Maximum Ratings	11
7	Operating Conditions	11
8	Block diagram	13
9	Block description.....	14
9.1	Array layout	14
10	Memories	14
10.1	RAM (Result Memory)	14
10.1.1	Configuraton register	16
10.1.2	Trimming register.....	17
10.2	EEPROM	18
10.3	POR.....	20
11	Communication protocol.....	20
11.1	Start / Stop condition	20
11.2	Device addressing	21
11.3	Acknowledge	21
11.4	EEPROM Communication	21
11.5	Sensor Communication	21
11.5.1	Measurement trigger.....	21
11.5.2	Read measurement data	22
IR data read.....		22
PTATdata read		23
Compensation pixel read.....		23
12	Device modes	23
12.1	Normal mode	23
12.2	Step mode	24
12.3	Power saving mode	24
13	Integrated Sensor for gradient compensation.....	24
14	Temperature calculation flow	26
14.1	Initialization	27
15	Calculation Considerations	28
15.1	Calculation of absolute temperature of the die (Ta)	28
15.2	Example for Ta calculations	29
15.3	Calculation of To	30
15.4	Calculating VIR(I,j)_COMPENSATED	31
15.5	Example for To calculations	34

16	Performance Graphs	37
16.1	Temperature accuracy	37
16.2	Noise performance and resolution	37
16.3	Calculated Field Of View (FOV)	39
17	Applications Information.....	40
17.1	Use of the HTPA 16x4 in I ² C configuration	40
18	Application Comments	40
19	Initialization.....	41
20	Liability	41
21	Glossar	42

3 Ordering Information

- HTPA → Heimann thermopile array
- a x b → number of elements
- Rx → Revision of the sensor
- L xx → „L“ lens cap TO39 followed by focal length of lens
- EA → optional ending “EA” for external aperture (L3.6 and L5.5 are only available with the external aperture)

Example: HTPA16x4R1L3.6EA

Currently available are:

- HTPA16x4R1L2.1
- HTPA16x4R1L2.85
- HTPA16x4R1L3.6EA (standard)
- HTPA16x4R1L5.5EA (standard)
- HTPA16x4R1L7.0

4 Pin Configuration

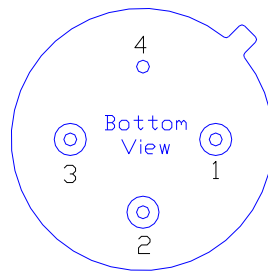

Figure 1: pin-allocation

Pin	Symbol	Description
1	SCL	Digital input, serial clock in SMBus compatible mode
2	SDA	Digital I/O, data input /output in SMBus compatible mode (open drain)
3	VDD	Positive supply voltage
4	VSS	Negative supply voltage / Ground (0V) (connected to housing)

5 Dimensional Drawings

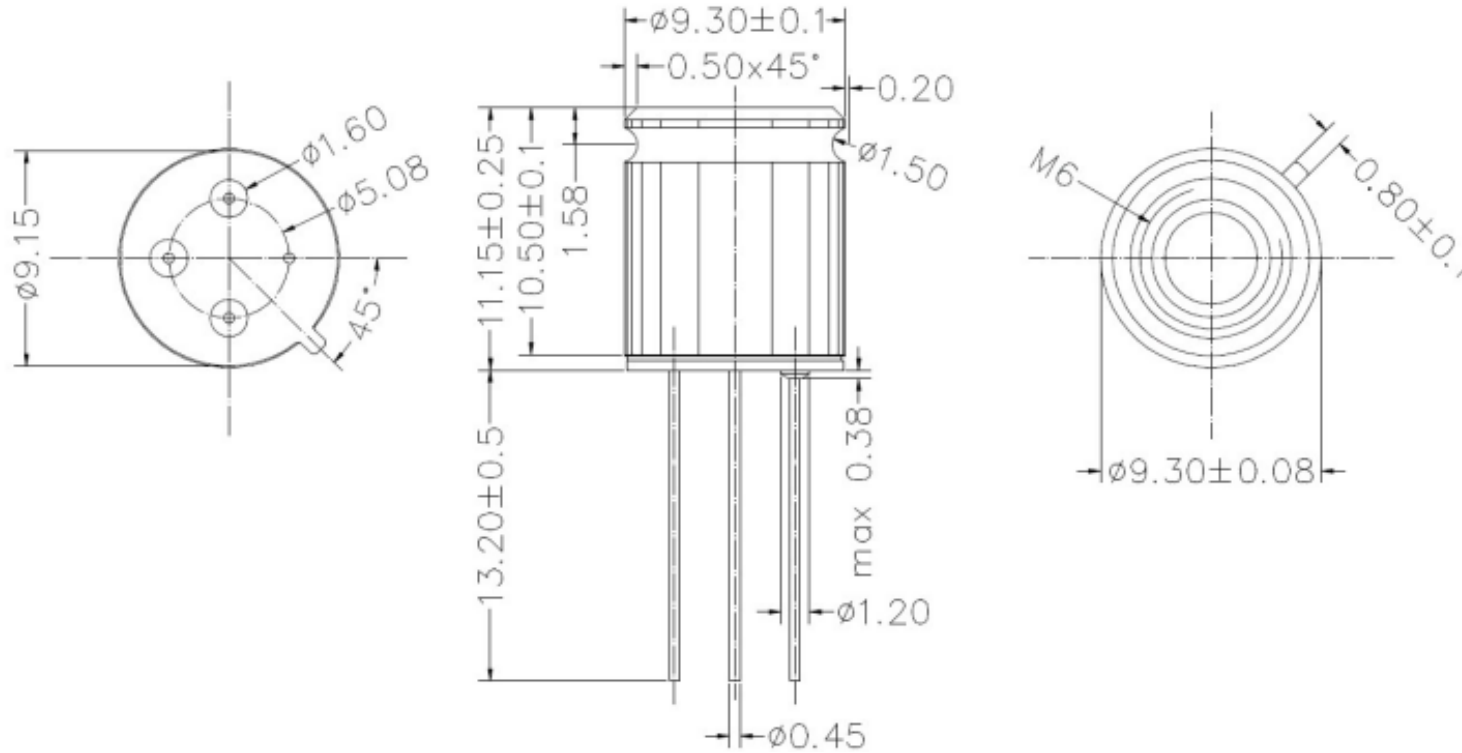

Figure 2: dimensional drawing of the HTPA16x4R1L3.6EA

Thermopile Array With Lens Optics
 Type HTPA 16x4R1
 Rev. 0: 20.08.2014 (Schnorr)

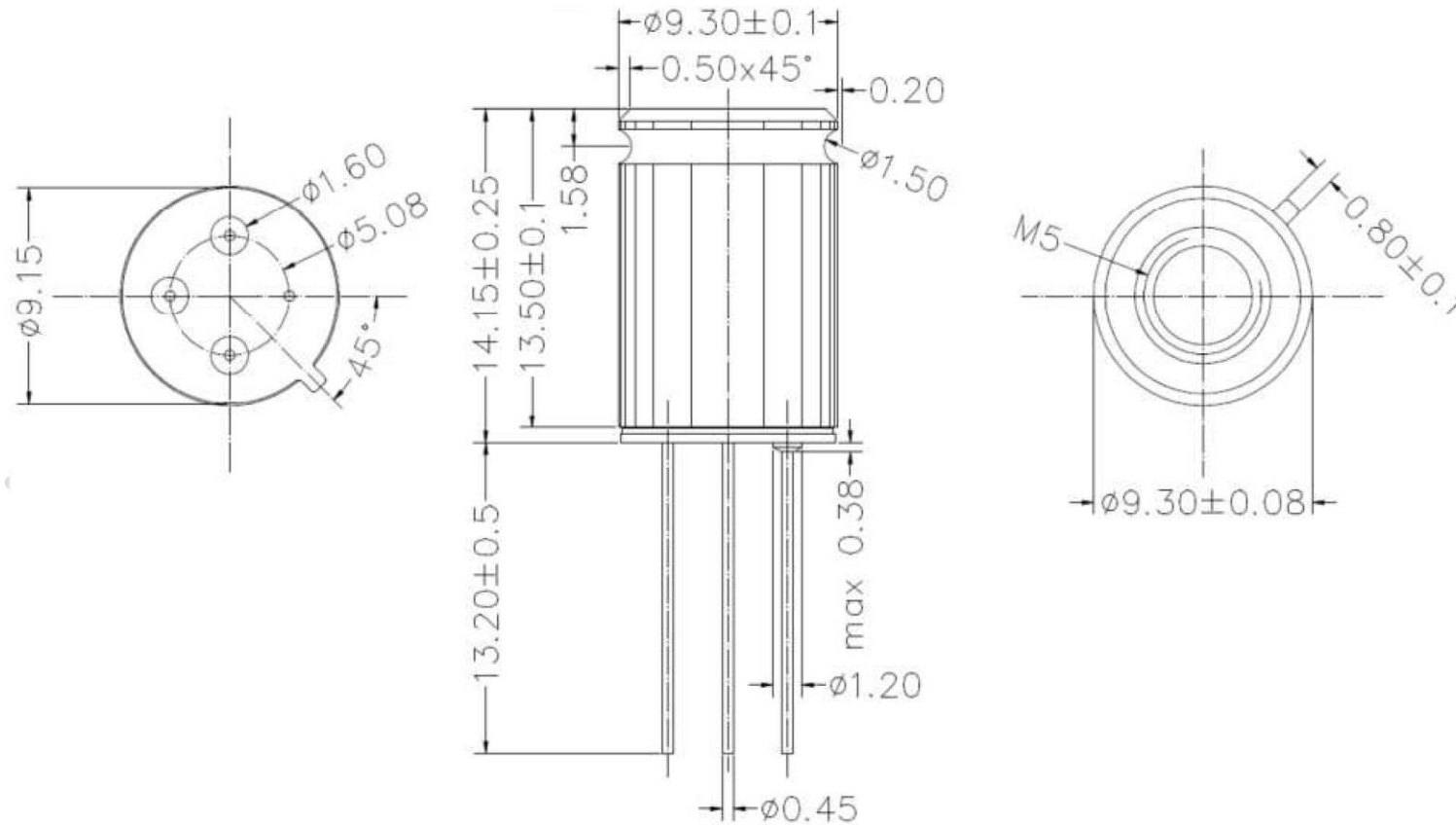

Figure 3: dimensional drawing of the HTPA16x4R1L5.5EA

Heimann Sensor GmbH
 Amtsgericht Dresden
 HRB 20692

Geschäftsführer:
 Dr. Jörg Schieferdecker
 Mischa Schulze
 Steuer-Nr.: 202/110/07487
 Ust-Ident-Nr.: DE 813444739

Ostsächsische Sparkasse Dresden
 SWIFT-Code: SOLADEST
 BIC: OSDDDE81XXX
 IBAN: DE03 8505 0300 3120 0454 02 (EUR)
 IBAN: DE40 8505 0300 0229 0000 88 (USD)

Commerzbank AG
 BIC: COBADEFF850
 IBAN: DE77 8504 0000 0800 4533 00

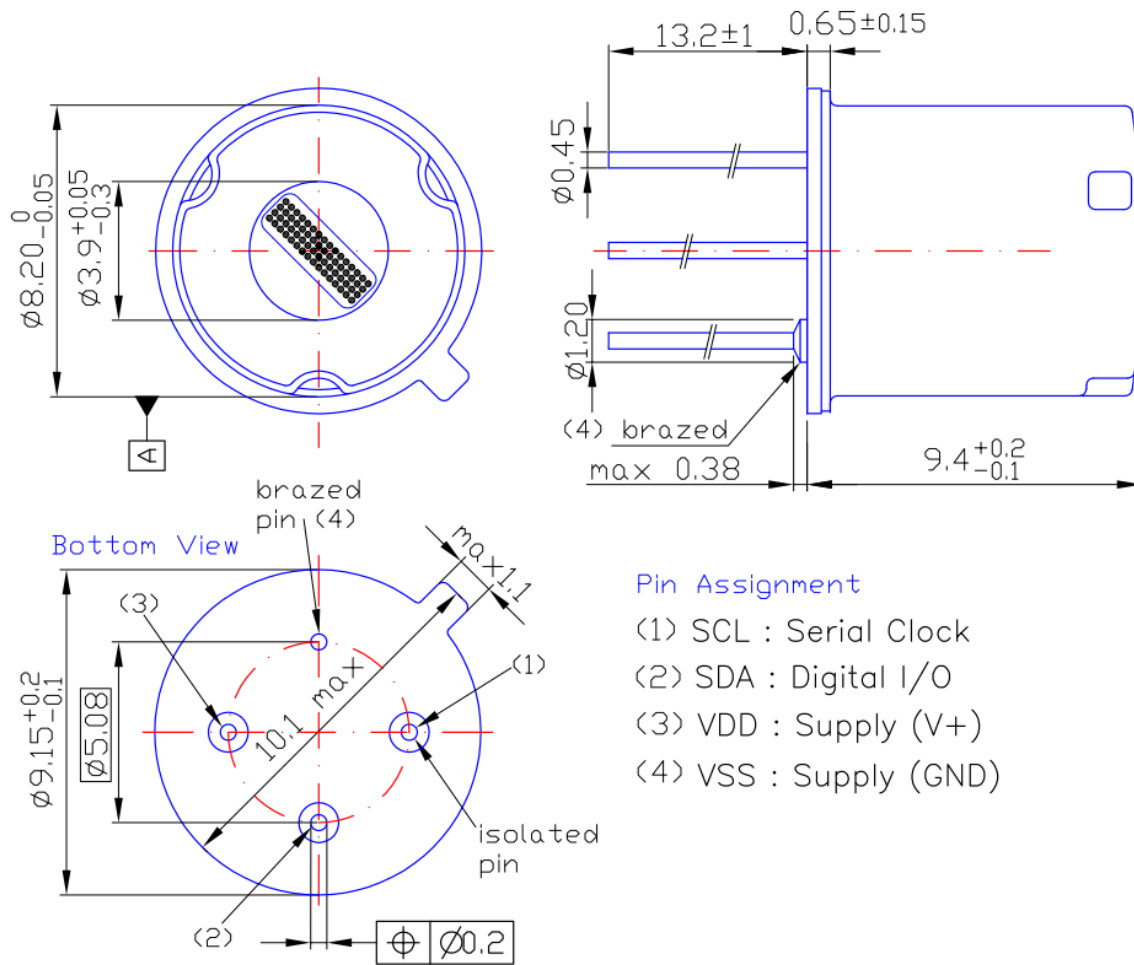

Figure 4: dimensional drawing of the HTPA16x4R1L7.0

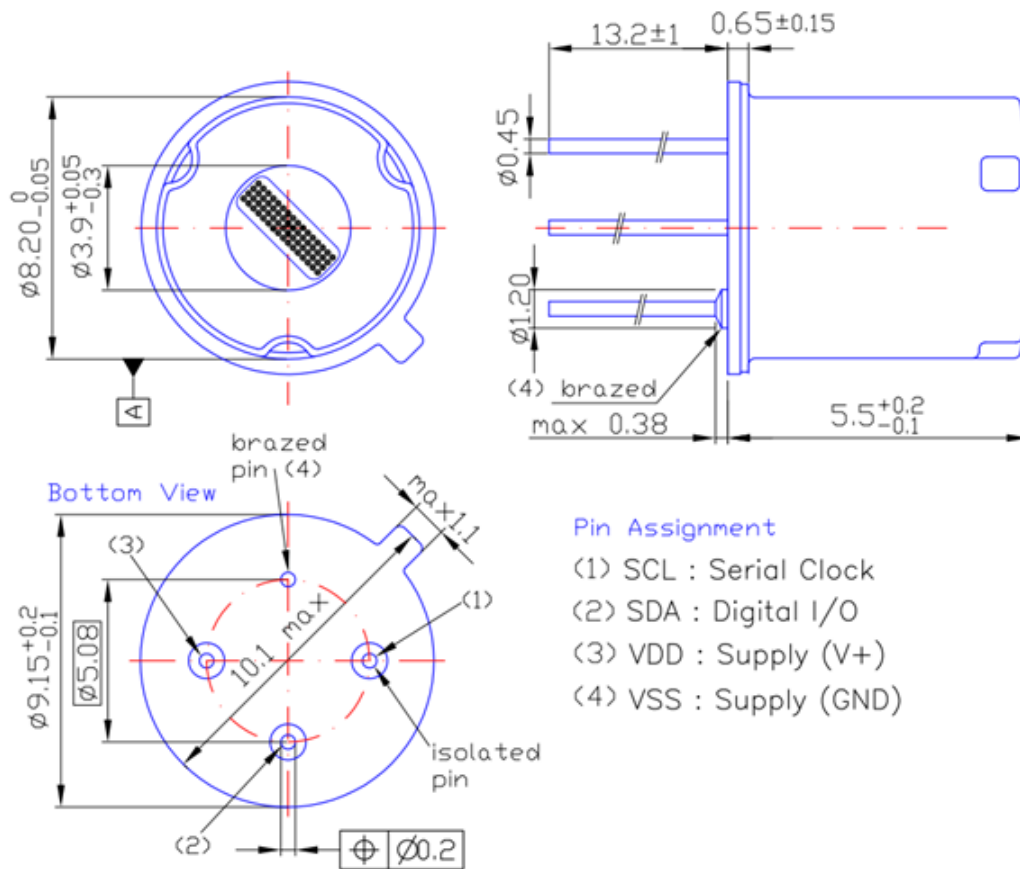

Figure 5: dimensional drawing of the HTPA16x4R1L2.85

6 Maximum Ratings

Tab 1: maximum ratings and values

Parameter	HTPA 16x4
Supply Voltage, VDD (over voltage)	5V
Supply Voltage, VDD (operating max)	3.6V
Reverse Voltage (each pin)	-0.3 V
Operating Temperature Range, TA	-40...+85°C
Storage Temperature Range, TS	-40...+125°C
ESD Sensitivity (AEC Q100 002)	2kV (4kV)
DC sink current, SDA	25 mA
DC source current, SDA	NA
DC clamp current, SDA	NA
DC source current, SCL	NA (input only)
DC clamp current, SCL	NA
Pitch	220 µm
Absorber size	Ø 170 µm
Pixel time constant	0.8 ms

Exceeding the absolute maximum ratings may cause permanent damage. Exposure to absolute-maximum-rated conditions for extended periods may affect device reliability.

7 Operating Conditions

All parameters are valid for $T_A = 25^\circ\text{C}$, $V_{DD} = 2.6\text{V}$ (unless otherwise specified)

Tab 2: operating conditions

Parameter	Symbol	Test Conditions	Min	Typ	Max	Units
Supplies						
External supply ¹	V_{DD}		2.5	2.6	3.3	V
Supply current	I_{DD}	No load	4	5	7	mA
Power On Reset						
POR level	V_{POR_up}	Power-up (full temp range)	2	2.2	2.4	V
POR level	V_{POR_down}	Power-down (full temp)	1.9	2.1	2.3	V
POR hysteresis	V_{POR_hys}	Full temp range		0.1		V
V_{DD} rise time (10% to 90% of specified supply)	T_{POR}	Ensure POR signal	100			µs
I²C compatible 2-wire interface²						
Slave address	SA	Factory default		60		hex
Input high voltage	$V_{IH}(T_a, V)$	Over temperature and supply	0.7V			V
Input low voltage	$V_{IL}(T_a, V)$	Over temperature and supply			0.3VD	V
Output low voltage	V_{OL}	SDA over temperature and supply, $I_{sink} = 6\text{mA}$ (FM)			0.6	V
Output low voltage	V_{OL}	SDA over temperature and supply, $I_{sink} = 20\text{mA}$ (FM+)			0.4	V
SCL leakage	$I_{SCL, leak}$	$V_{SCL} = 4\text{V}$, $T_a = +85^\circ\text{C}$			2	µA
SDA leakage	$I_{SDA, leak}$	$V_{SDA} = 4\text{V}$, $T_a = +85^\circ\text{C}$			2	µA

SCL capacitance	C _{SCL}				20	pF
Clock frequency	SCL _{IR}				1	MHz
Acknowledge setup time	Tsuac(MD)	8-th SCL falling edge, Master			0.45	µs
Acknowledge hold time	Thdac(MD)	9-th SCL falling edge, Master			0.45	µs
Acknowledge setup time	Tsuac(SD)	8-th SCL falling edge, Slave			0.45	µs
Acknowledge hold time	Thdac(SD)	9-th SCL falling edge, Slave			0.45	µs
EEPROM						
Slave address	SA	Factory default		50		hex
Clock frequency	SCL _{EEPROM}				400	kHz
Data retention		Ta = +85°C	200			years
Erase/write cycles		Ta = +25°C	1M			Times
Erase/write cycles		Ta = +125°C	100K			Times
Erase cell time	T _{erase}				5	ms
Write cell time	T _{write}				5	ms

- 1) The device can be supplied with 2.5...3.3 V but the best performance is achieved at VDD=2.6V. For supply voltages above 2.7V a compensation algorithm should be applied for accurate temperature readings.

8 Block diagram

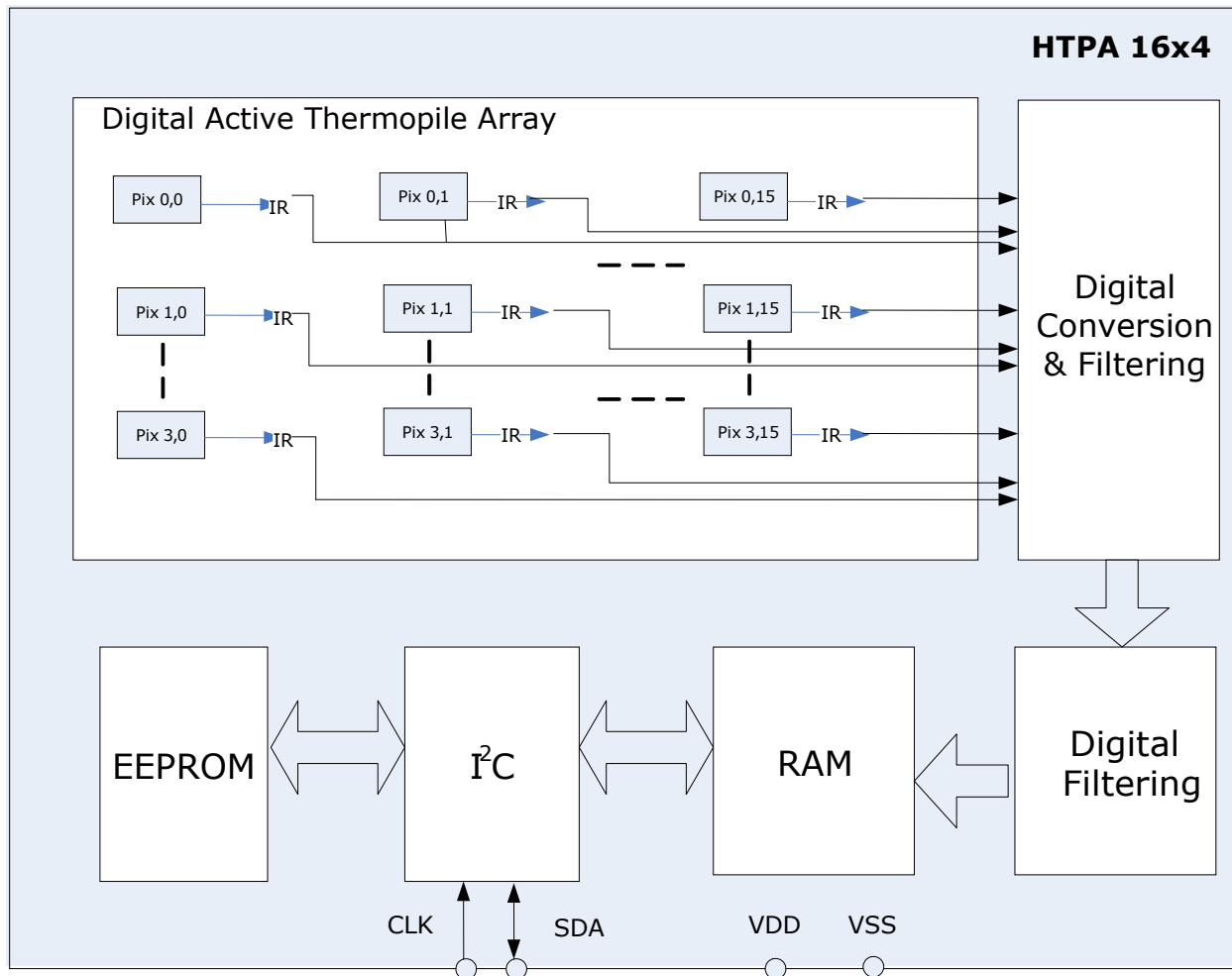

Figure 6: block diagram

The device consists of 2 chips packed in single TO-39 package

- IR array and processing electronics
- EEPROM chip

9 Block description

9.1 Array layout

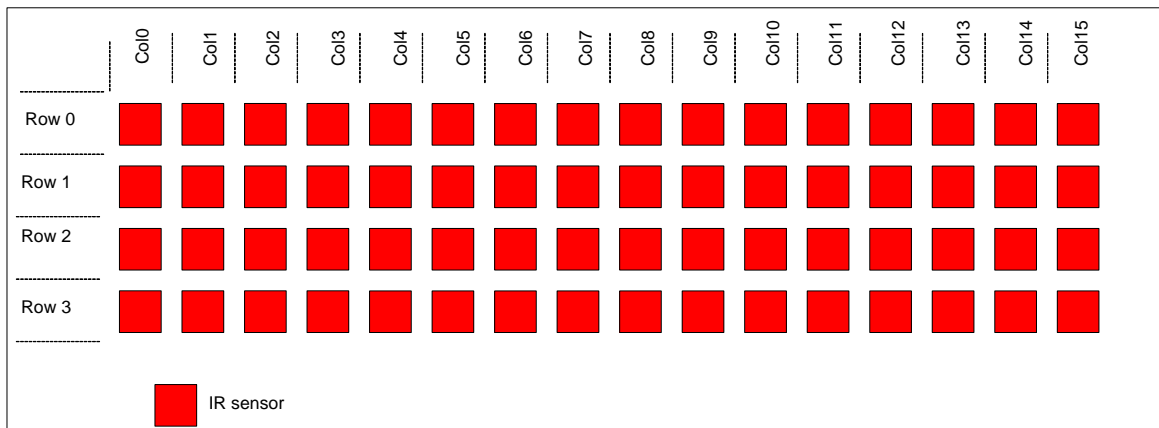

Figure 7: array layout of IR sensors

The array consists of 64 IR sensors (called also pixels). Each pixel is identified with its row and column position as $Pix(i,j)$ where i is its row number and j is its column number (from 0 to 15).

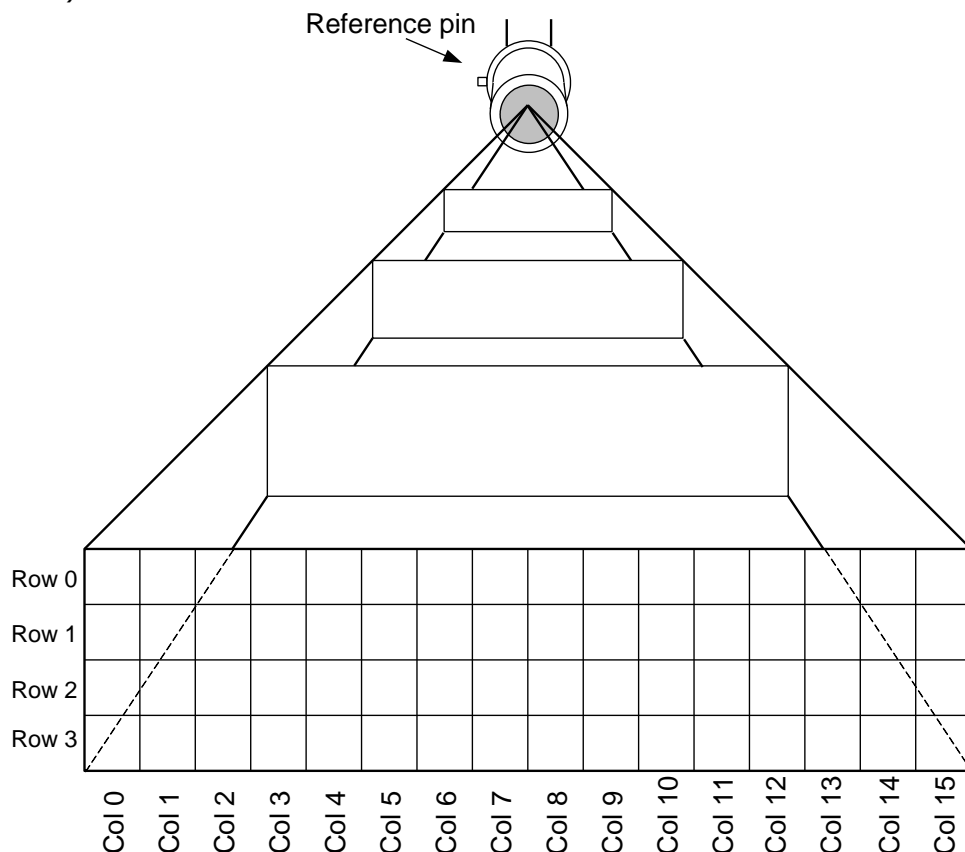

Figure 8: assignment from inside alignment to external reference pin

10 Memories

10.1 RAM (Result Memory)

Heimann Sensor GmbH
 Amtsgericht Dresden
 HRB 20692
 0800 4533 00

Geschäftsführer:
 Dr. Jörg Schieferdecker
 Mischa Schulze

Steuer-Nr.: 202/110/07487
 Ust-Ident-Nr.: DE 813444739

Ostsächsische Sparkasse Dresden
 SWIFT-Code: SOLADEST
 BIC: OSDDDE81XXX

IBAN: DE03 8505 0300 3120 0454 02 (EUR)
 IBAN: DE40 8505 0300 0229 0000 88 (USD)

Commerzbank AG
 BIC: COBADEFF850
 IBAN: DE77 8504 0000

The on chip 146x16 RAM is accessible for reading via I²C. The RAM is used for storing the results of measurements of pixels and Ta sensor and is distributed as follows:

- 64 words for IR sensors. The data will be in 2's complement format
- 1 word for measurement result of PTAT sensor. This sensor is selected to be a reference Ta for the device. The temperatures of all other Ta sensors are measured relative to this one. The data is 16 bit without sign. Physically this sensor is placed close to IR(1,1).

Tab. 3: RAM map

Address	RAM variable description
0x00	IR sensor (0,0) result
0x01	IR sensor (1,0) result
0x02	IR sensor (2,0) result
0x03	IR sensor (3,0) result
0x04	IR sensor (0,1) result
0x05	IR sensor (1,1) result
0x06	IR sensor (2,1) result
0x07	IR sensor (3,1) result
...	...
0x3C	IR sensor (0,15) result
0x3D	IR sensor (1,15) result
0x3E	IR sensor (2,15) result
0x3F	IR sensor (3,15) result
0x40	PTAT sensor result
0x41	Compensation sensor result
0x92	Configuration register
0x93	Trimming register

10.1.1 Configuraton register

The configuration register defines the chip operating modes.
 It can be read and written by the I²C MD.

Tab. 4: configuration register map

15	14	13	12	11	10	9	8	7	6	5	4	3	2	1	0	configuration register bit meaning (0x92)
												0	0	0	0	- IR Refresh rate = 512Hz
												0	0	0	1	- IR Refresh rate = 512Hz
												0	0	1	0	- IR Refresh rate = 512Hz
												0	0	1	1	- IR Refresh rate = 512Hz
												0	1	0	0	- IR Refresh rate = 512Hz
												0	1	0	1	- IR Refresh rate = 512Hz
												0	1	1	0	- IR Refresh rate = 256Hz
												0	1	1	1	- IR Refresh rate = 128Hz
												1	0	0	0	- IR Refresh rate = 64Hz
												1	0	0	1	- IR Refresh rate = 32Hz
												1	0	1	0	- IR Refresh rate = 16Hz
												1	0	1	1	- IR Refresh rate = 8Hz
												1	1	0	0	- IR Refresh rate = 4Hz
												1	1	0	1	- IR Refresh rate = 2Hz
												1	1	1	0	- IR Refresh rate = 1Hz (default)
												1	1	1	1	- IR Refresh rate = 0.5Hz
											0	0	15	- bit resolution*		
											0	1	16	- bit resolution*		
											1	0	17	- bit resolution*		
											1	1	18	- bit resolution*		
											0	- continuous measurement mode - (default)				
											1	- step measurement mode				
											0	- Normal operation mode- (default)				
											1	- sleep mode				
											x	NA				
											0	- No IR measurement running (Flag only, cannot be written)				
											1	- IR measurement running (Flag only, cannot be written) - (default)				
											0	- POR or Brown out occured - Need to reload configuration register				
											1	- MD must write "1" during uploading configuration register - (default)				
											0	- I2C FM + mode enabled (max bit transfer rates up to 1000kbits/s) - (default)				
											1	- I2C FM + mode disabled (max bit transfer rates up to 400kbits/s)				
											0	0	EEPROM enabled			
											0	1	EEPROM disabled			
											0	Heimann Sensor reserved				
											1	Heimann Sensor reserved				
											0	Heimann Sensor reserved				

* Depending on bits [5:4], the RAM readout represents x2, x4, x8 increased resolution while maintaining the 16 bits data. This has the effect that for higher resolution readouts, the maximum measureable temperature is reduced (see 16.2).

10.1.2 Trimming register

Tab. 5: trimming register

15	14	13	12	11	10	9	8	7	6	5	4	3	2	1	0	Trimming register bit meaning (0x93)
										7 bit value					- Oscillator trim value	
x	x	x	x	x	x	x	x	x	x	NA						

Opcode – 0x04.

This command is used to set the trimming parameters – oscillator, bandgap, current source trimming bits values. It can be read and written by the I²C MD.

Simple data check is introduced. The two data bytes are sent two times: first time with the true data minus 0xAA and second time – the true data. The chip does the addition with 0xAA internally and checks the second received byte. Only if the addition results match with the received data for the two bytes, the configuration register is updated. The command communication is illustrated below:

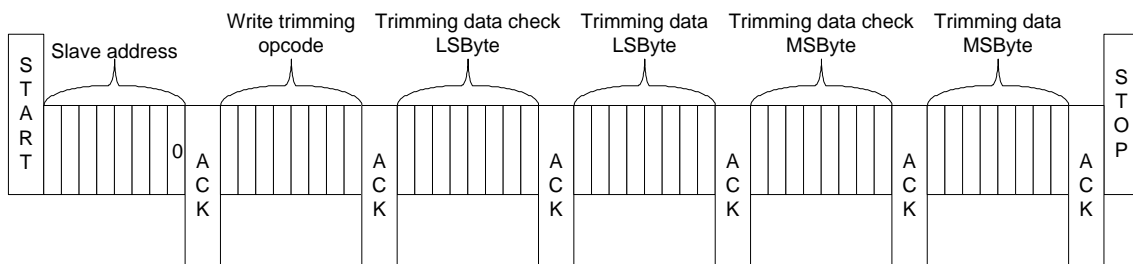

10.2 EEPROM

A 2kbit, organized as 256x8 EEPROM is built in the HTPA 16x4. The EEPROM is on a separate die (separate SA = 0x50) and is used to store the calibration constants and the configuration of the device.

Tab. 6: EEPROM map

Address	0	1	2	3	4	5	6	7
00	ai(0,0)	ai(1,0)	ai(2,0)	ai(3,0)	ai(0,1)	ai(1,1)	ai(2,1)	ai(3,1)
08	ai - IR pixels individual offset coefficients							
10								
18								
20								
28								
30								
38	ai(0,14)	ai(1,14)	ai(2,14)	ai(3,14)	ai(1,15)	ai(2,15)	ai(3,15)	
40	bi(0,0)	bi(1,0)	bi(2,0)	bi(3,0)	bi(0,1)	bi(1,1)	bi(2,1)	bi(3,1)
48	bi - Individual Ta dependence (slope) of IR pixels offset							
50								
58								
60								
68								
70								
78	bi(0,14)	bi(1,14)	bi(2,14)	bi(3,14)	bi(1,15)	bi(2,15)	bi(3,15)	
80	$\Delta\alpha(0,0)$	$\Delta\alpha(1,0)$	$\Delta\alpha(2,0)$	$\Delta\alpha(3,0)$	$\Delta\alpha(0,1)$	$\Delta\alpha(1,1)$	$\Delta\alpha(2,1)$	$\Delta\alpha(3,1)$
88	Individual sensitivity coefficients							
90								
98								
A0								
A8								
B0								
B8	$\Delta\alpha(0,14)$	$\Delta\alpha(1,14)$	$\Delta\alpha(2,14)$	$\Delta\alpha(3,14)$	$\Delta\alpha(0,15)$	$\Delta\alpha(1,15)$	$\Delta\alpha(2,15)$	$\Delta\alpha(3,15)$
C0	Heimann Sensor reserved							
C8								
D0								
D8	TGC	Scale offset	PTAT					
E0	common sensitivity coefficients				Emissivity		KsTa	
E8	Heimann Sensor reserved							
F0							Config register	OSC trim
F8	Chip ID							

Detailed descriptions of some EEPROM addresses are depicted here after:

Tab. 7: D7...D0 EEPROM cell meaning – Compensation pixel constants

D7	D6	D5	D4	D3	D2	D1	D0	EEPROM cell meaning
						AcommonH	AcommonL	- common offset
					KT	[7:4] – KT1 scale		
					scale	[3:0] – KT2 scale - 10		
			a _{CPH}	a _{CPL}				- Compensation pixel individual offset
		b _{CP}						- Individual Ta dependence (slope) of the compensation pixel offset
Δα _{cp_H}	Δα _{cp_L}							- Sensitivity coefficient of the compensation pixel

Tab. 8: DF...D8 EEPROM cell meaning – PTAT constants

DF	DE	DD	DC	DB	DA	D9	D8	EEPROM cell meaning
								- Thermal Gradient Coefficient
						Offset	[7:4] - Aiscale	
						scale	[3:0] - Biscale	
			V _{th_H}	V _{th_L}				- Vth0 of absolute temperature sensor
		KT1_H	KT1_L					- KT1 of absolute temperature sensor
KT2_H	KT2_L							- KT2 of absolute temperature sensor

Tab. 9: E7...E0 EEPROM cell meaning

E7	E6	E5	E4	E3	E2	E1	E0	EEPROM cell meaning
						α _{0_H}	α _{0_L}	- Common sensitivity coefficient
					α _{0scale}			- Common sensitivity coefficient
				Δα _{scale}				- Individual sensitivity scaling coefficient
		ε _H	ε _L					- Emissivity coefficient
Heimann Sensor reserved								

Tab. 10: F7...F0 EEPROM cell meaning

F7	F6	F5	F4	F3	F2	F1	F0	EEPROM cell meaning
								Heimann Sensor reserved
	CFG _H	CFG _L						- Config register value
OSC_trim								- Oscillator trimming value

10.3 POR

The Power On Reset (POR) is connected to the Vdd supply. The on-chip POR circuit provides an active level of the POR signal when the Vdd voltage rises above approximately 0.5V and holds the entire HTPA 16x4 in reset until the Vdd is higher than 2.4V. The device will start approximately 5 ms after the POR release.

11 Communication protocol

The device supports Fast Mode Plus I²C FM+ (up to 1Mbps) and will work in slave mode only.

See full I²C specification at: http://www.nxp.com/documents/user_manual/UM10204.pdf

The communication is running through 2 digital pins: SCL and SDA. The master device is providing the clock signal SCL for the communication. The data line SDA is driven by either the master or the slave depending on the direction of the communication. A '0' is transmitted by pulling the SDA line to 'LOW' and a '1' by releasing it 'HIGH'. During the data transfer the SDA must remain stable while SCL is HIGH. Changes in SDA are allowed only when SCL is LOW.

11.1 Start / Stop condition

Each communication session is initiated by a START condition and ends with a STOP condition. A START condition is initiated by a HIGH to LOW transition of the SDA while a STOP is generated by a LOW to HIGH transition. Both changes must be done while the SCL is HIGH (see the figure)

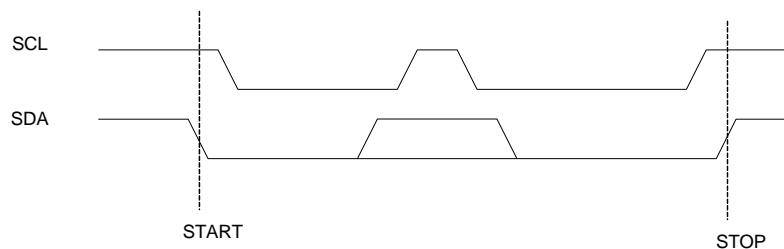

Figure 9: Start / Stop conditions of I²C

11.2 Device addressing

The master is addressing the slave device by sending a 7-bit slave address + R/W bit after the START condition. This bit indicates the direction of the transfer:

- Read (HIGH) means that the master will read the data from the slave
- Write (LOW) means that the master will send data to the slave

HTPA 16x4 is responding to 2 different slave addresses:

1	0	1	0	0	0	0	R \bar{W}
---	---	---	---	---	---	---	-------------

for access to internal EEPROM

1	1	0	0	0	0	0	R \bar{W}
---	---	---	---	---	---	---	-------------

for access to IR array chip

11.3 Acknowledge

During the 9th clock following every byte transfer the transmitter releases the SDA line. The receiver acknowledges (ACK) receiving the byte by pulling SDA line to low or does not acknowledge (NoACK) by letting the SDA high.

11.4 EEPROM Communication

For further information see datasheet of 24AA02.

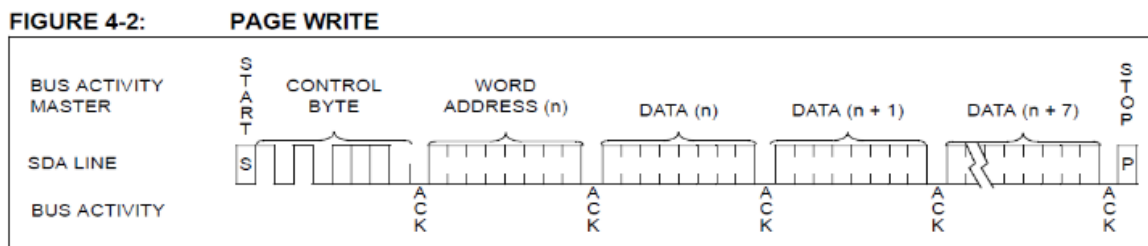

11.5 Sensor Communication

11.5.1 Measurement trigger

After the initialization procedure is done depending on the selected measurement mode (bit 6 in the configuration register) there are two possible routines:

- continuous mode
 - wait for valid data (depending on chosen refresh rates – IR and PTAT)
- Step mode
 - Send start measurement command

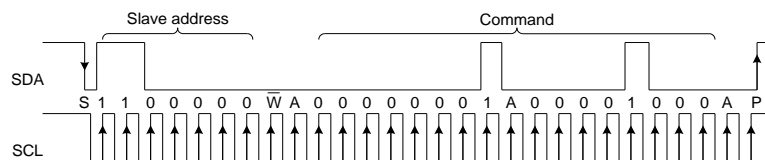

Figure 10: Start measurement command (SA = 0x60, command = 0x0801)

- Wait certain time

- Wait for the ready flag to be set

11.5.2 Read measurement data

IR data read

There are four options available for reading IR data:

- Whole frame read (Heimann Sensor recommends the whole frame read for maximum refresh rate)

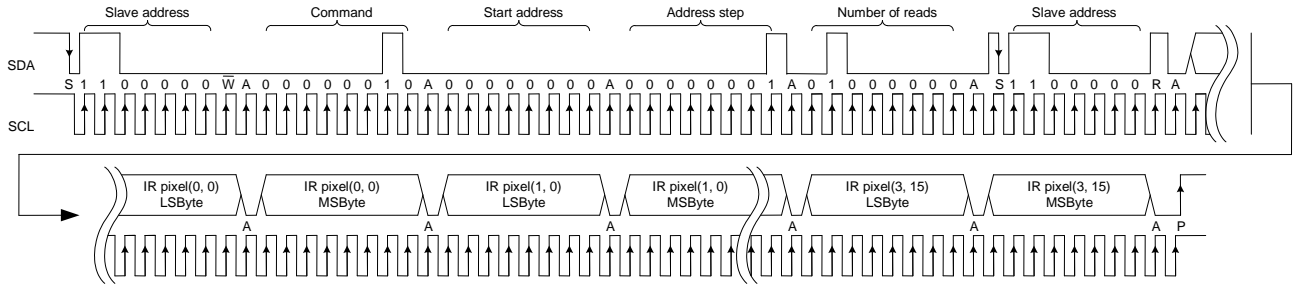

Figure 11 Whole frame (SA = 0x60, command = 0x02, Start address = 0x00, Address step = 0x01, Number of reads = 0x40) measurement result read

- Single column read

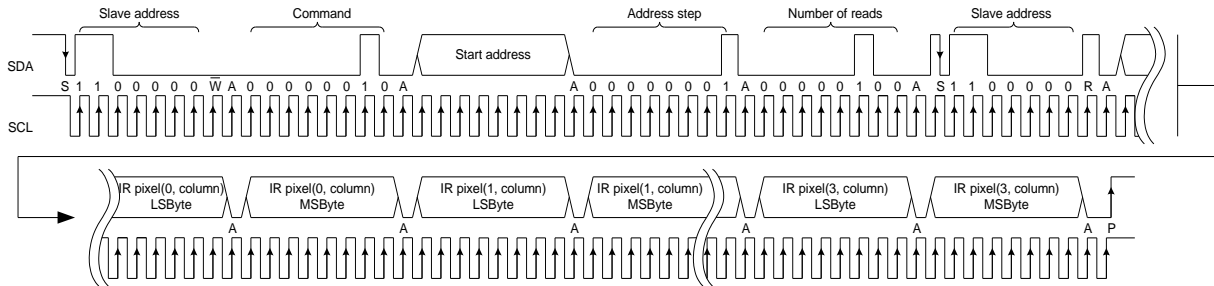

Figure 12 Single column (SA = 0x60, command = 0x02, Start address = 0x00...0x3C (step 0x04), Address step = 0x01, Number of reads = 0x04) measurement result read

- Single line read

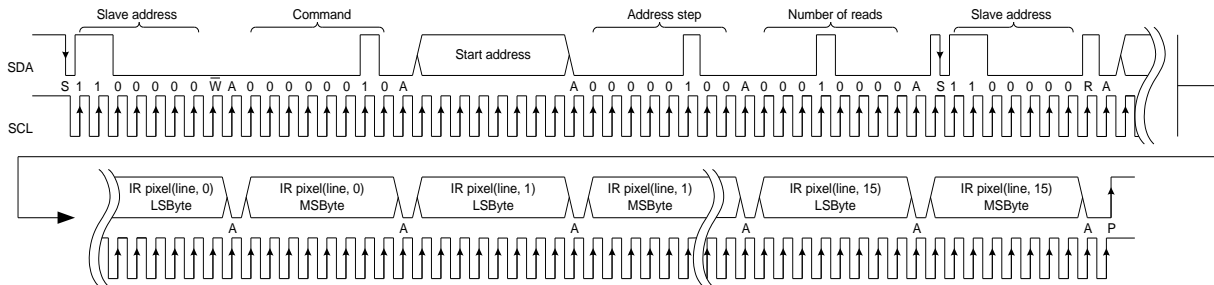

Figure 13 Single line (SA = 0x60, command = 0x02, Start address = 0x00...0x03 (step 0x01), Address step = 0x04, Number of reads = 0x10) measurement result read

- Single pixel read

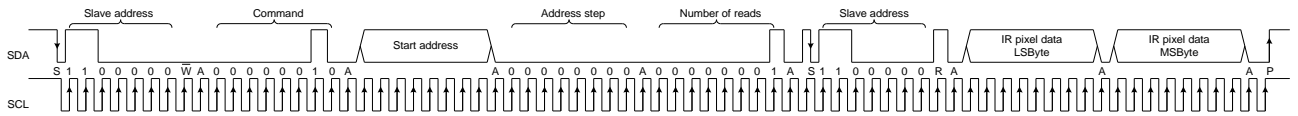

Figure 14 Single pixel (SA = 0x60, command = 0x02, Start address = 0x00...0x3F, Address step = 0x00, Number of reads = 0x01) measurement result read

PTATdata read

Absolute ambient temperature data of the device itself (package temperature) can be read by using following command:

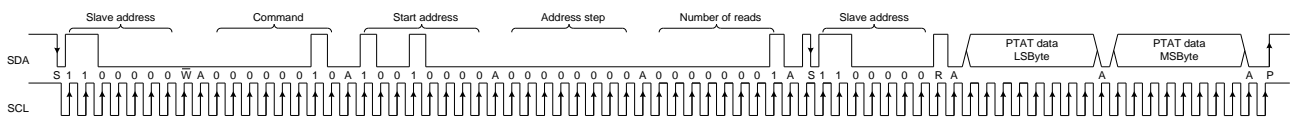

Figure 15: PTAT (SA = 0x60, command = 0x02, Start address = 0x90, Address step = 0x00, Number of reads = 0x01) measurement result read

$$PTAT_data = \{ PTAT_data_MSbyte : PTAT_data_LSbyte \}$$

Compensation pixel read

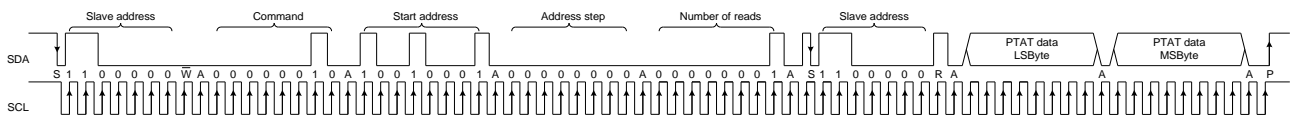

Figure 16 Compensation pixel (SA = 0x60, command = 0x02, Start address = 0x91, Address step = 0x00, Number of reads = 0x01) measurement result read

The 16bit data for each pixel is:

$$IR(i, j)_data = \{ IR(i, j)_data_MSbyte : IR(i, j)_data_LSbyte \}$$

12 Device modes

The device can operate in following modes:

- Normal mode
- Step mode
- Power saving mode

12.1 Normal mode

In this mode the measurements are constantly running. Depending on the selected refresh rate Fps in ConfReg, the data for IR pixels and Ta will be updated in the RAM each 1/Fps seconds. In this mode the external microcontroller has full access to the internal registers and memories of the device (both for HTPA 16x4 and EEPROM chip).

12.2 Step mode

This mode is foreseen for single measurements triggered by the external device (microcontroller). Entering this mode is possible by writing the appropriate code in ConfReg. A measurement is triggered by sending the command StartMeas. On detecting the command, the HTPA 16x4 will start the measurements immediately after the I²C session is finished (STOP condition detected). The measurement time is 1/Fps and can be selected in 2 possible ways:

- The already programmed Fps parameter in ConfReg can be used and the measurement (integration) time will take 1/Fps
- The Fps parameter can be an argument in the StartMeas command.

Once the Step mode is initiated the access to the internal registers of the device will be disabled. If the master sends a command to the HTPA 16x4 while the measurement in step mode is ongoing, a NoAckn will be received after the slave address is transmitted.

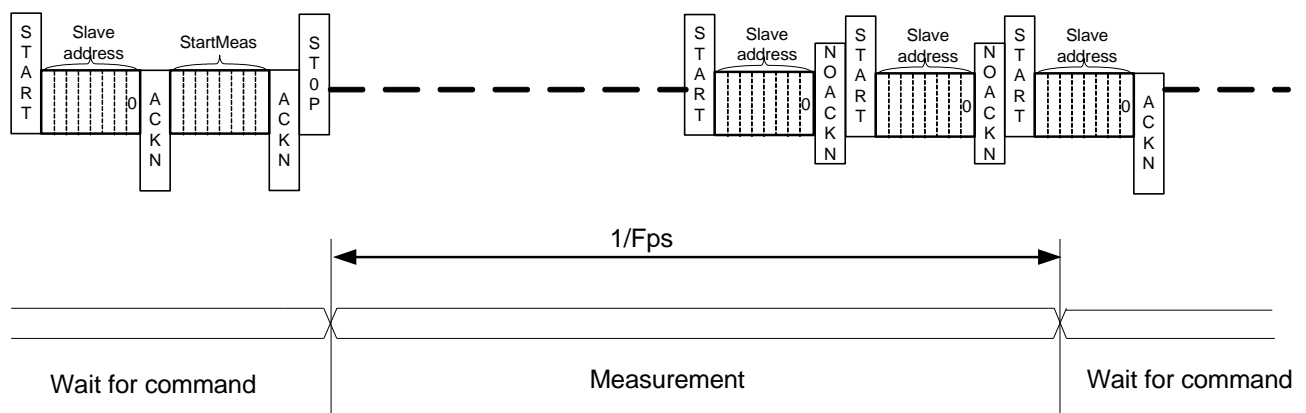

Figure 17: Execution of Start_Meas in Step mode

12.3 Power saving mode

In this mode the device will be completely shutdown and the current consumption will be minimized to less than 5 µA. Entering this mode is initiated by sending the command 'Sleep'. Upon receiving it the device will shutdown all electronics, including the internal oscillator. The chip will monitor the I²C line. Each START condition will wake up the oscillator and the chip will receive and evaluate the slave address. If the address is 0x60 (address programmed in HTPA 16x4) the device will evaluate the whole command and will execute it. If not, the oscillator will be switched off again.

13 Integrated Sensor for gradient compensation

The IR sensor readings and accuracy are very sensitive to any temperature gradients over the package. Any temperature difference between the cold junction of thermopile and (part of) the package, 'seen' by the IR sensor will create an error signal. Such a problem is not very severe for the applications where absolute measurement is not required, because in this case it is important to cancel the distortion.

However for the applications where the picture must be converted to temperatures, seen by the different pixels, such a gradient will introduce huge error in the measurement. The problem will be even more severe if there is a variation of the gradient (unfortunately the most common case, because the gradient comes from power dissipation of electronics on the same pcb, which varies with environmental conditions).

The HTPA16x4 supports one extra IR channel containing amplifier, ADC and digital filter. The input of this chain is connected to bond pads. An additional IR sensor can be placed

Thermopile Array With Lens Optics
Type HTPA 16x4R1
Rev. 0: 20.08.2014 (Schnorr)



in the same package and connected to these bond pads. If this sensor is optically 'blinded' (seeing only package, not outside) its output can be used to compensate the error readings of the main array.

Heimann Sensor has developed and implemented this approach successfully. The experience shows that the readings of additional sensor allow reduction of the gradient's error by factor of 10.

Heimann Sensor GmbH
Amtsgericht Dresden
HRB 20692
0800 4533 00

Geschäftsführer:
Dr. Jörg Schieferdecker
Mischa Schulze

Steuer-Nr.: 202/110/07487
Ust-Ident-Nr.: DE 813444739

Ostsächsische Sparkasse Dresden
SWIFT-Code: SOLADEST
BIC: OSDDDE81XXX

IBAN: DE03 8505 0300 3120 0454 02 (EUR)
IBAN: DE40 8505 0300 0229 0000 88 (USD)

Commerzbank AG
BIC: COBADEFF850
IBAN: DE77 8504 0000

14 Temperature calculation flow

The following algorithm shows an example of a program execution flow to achieve object as well as ambient temperatures.

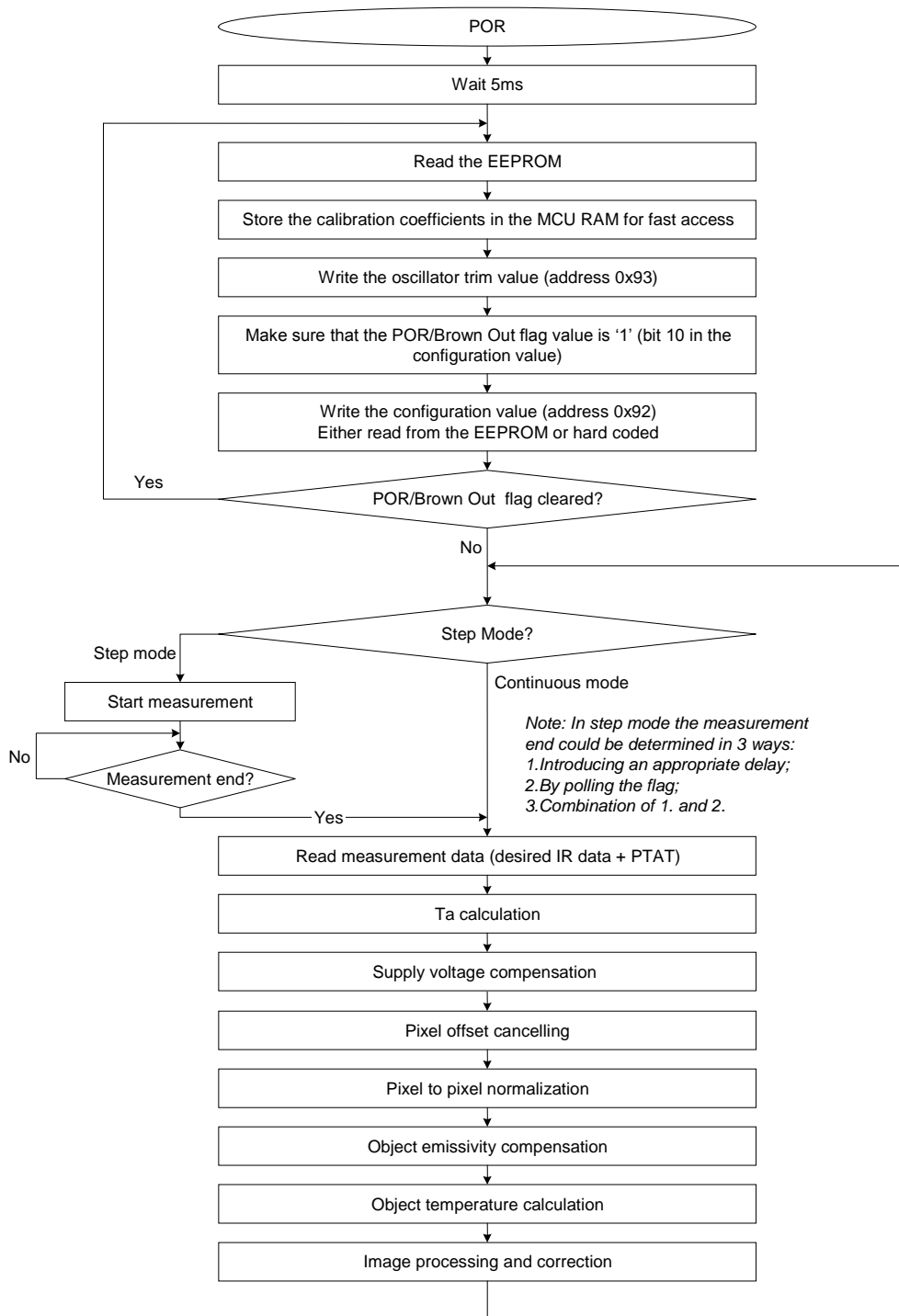

Figure 18: temperature calculation flow

14.1 Initialization

After the POR is released the external CPU must execute an initialization procedure. This procedure must start at least 5ms after POR release.

- Read the whole EEPROM (see Figure 19). For maximum speed performance Heimann Sensor recommends that the whole calibration data is stored into the client MCU RAM. However it is possible to read the calibration data from the EEPROM only when needed. This will result in increased time for temperature calculation i.e. low refresh rate.

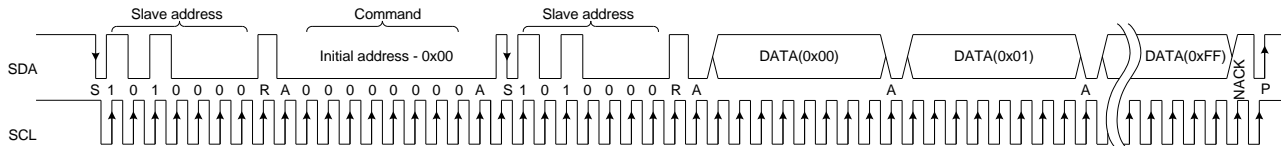

Figure 19 Whole EEPROM dump (SA = 0x50)

- Store the EEPROM content into customer MCU RAM (see above paragraph for optional information)
- Write the oscillator trimming value (extracted from EEPROM content at address 0xF7) into the corresponding register (0x93).

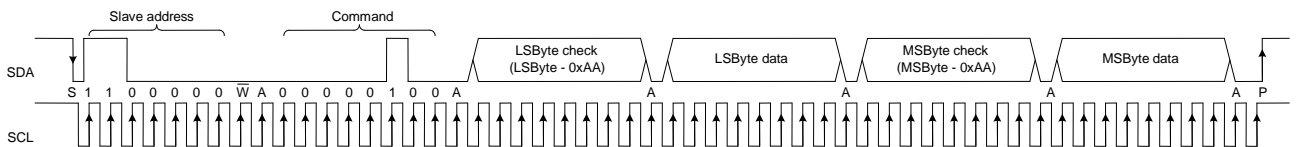

Figure 20 Write oscillator trimming (SA = 0x60, command = 0x04)

- Write device configuration value. In EEPROM addresses (0xF5 and 0xF6) Heimann Sensor provides a typical value of the configuration register (0x740E). So it is up to the user to copy that value or hardcode a new value to be loaded into the configuration register. If the EEPROM value is to be used the 16 bits are combined as follows:

For instance if EEPROM 0xF5 = 0x0E and 0xF6 = 0x74, the Configuration register value is:

$$\text{Configuration_register_value} = \{0xF6 : 0xF5\} = 0x740E$$

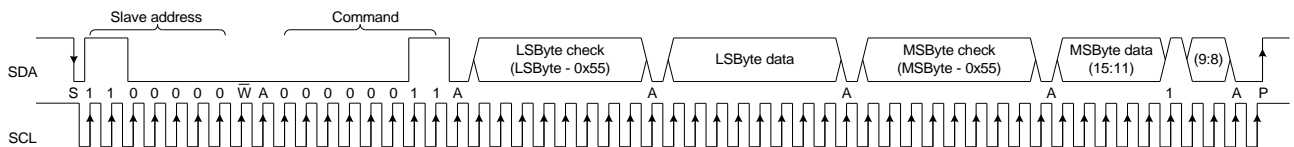

Figure 21 Write configuration register (SA = 0x60, command = 0x03)

NOTE: The customer must ensure that the bit 10 (POR or Brown-out flag) in Configuration register is set to "1" by the MD. Furthermore this bit must be checked regularly and if it is cleared that means that the device has been reset and the initialization procedure must be redone.

Opcode – 0x03.

This command is used to set the configuration register (16bits) value – all configuration settings.

Simple data check is introduced. The two data bytes are sent two times: first time with the true data minus 0x55 and second time – the true data. The chip does the addition with 0x55 internally and checks the second received byte. Only if the addition results match with the received data for the two bytes, the configuration register is updated.

The command communication is illustrated below:

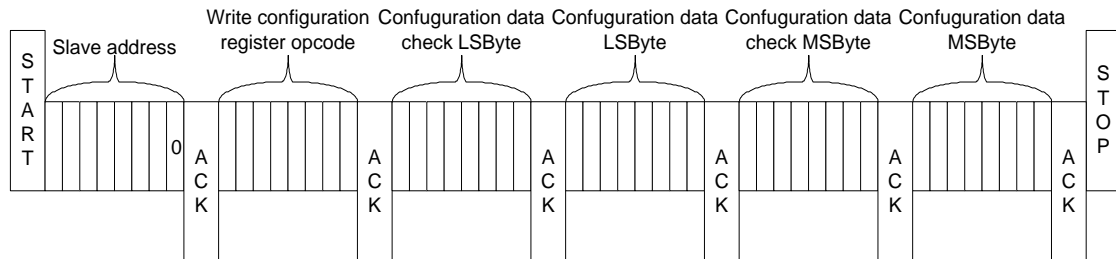

Figure 22: Write configuration register command

The default configuration is:

- IR refresh rate = 1Hz
- Ta refresh rate = 0.5Hz
- Continuous measurement mode
- Normal mode (no sleep)
- I²C FM+ mode (max bit transfer rates up to 1000 kbit/s) enabled
- ADC low reference enabled

15 Calculation Considerations

15.1 Calculation of absolute temperature of the die (Ta)

The output signal of the IR sensor is relative to its cold junction temperature. That is why we need to know the absolute temperature of the die in order to be able to calculate the object temperature 'seen' by each pixel.

The Ta can be calculated using the formula:

$$T_a = \frac{-K_{T1} + \sqrt{K_{T1}^2 - 4K_{T2}[V_{TH}(25) - PTAT_data]}}{2K_{T2}} + 25, [^{\circ}\text{C}]$$

Constants $V_{TH}(25)$, K_{T1} and K_{T2} are stored in EEPROM at following addresses as two's complement values:

Tab. 11: absolute temperature values storage address

EEPROM address	Cell name	Stored as	Parameter
0xDA	V_{TH_L}	2's complement	V_{TH0} of absolute temperature sensor
0xDB	V_{TH_H}		
0xDC	K_{T1_L}	2's complement	K_{T1} of absolute temperature sensor
0xDD	K_{T1_H}		
0xDE	K_{T2_L}	2's complement	K_{T2} of absolute temperature sensor
0xDF	K_{T2_H}		
0xD2	K_{T_scale}	unsigned	[7:4] - K_{T1_scale} [3:0] - K_{T2_scale}

$$V_{TH}(25) = 256 \cdot V_{TH_H} + V_{TH_L}$$

$$\text{If } V_{TH}(25) > 32767 \rightarrow V_{TH}(25) = V_{TH}(25) - 65536$$

$$V_{TH}(25) = \frac{V_{TH}(25)}{2^{3-ConfigReg[5:4]}}$$

$$K_{T1} = 256 \cdot K_{T1_H} + K_{T1_L}$$

$$\text{If } K_{T1} > 32767 \rightarrow K_{T1} = K_{T1} - 65536$$

$$K_{T1} = \frac{K_{T1}}{2^{K_{T1_scale}} \cdot 2^{3-ConfigReg[5:4]}}$$

$$K_{T2} = 256 \cdot K_{T2_H} + K_{T2_L}$$

$$\text{If } K_{T2} > 32767 \rightarrow K_{T2} = K_{T2} - 65536$$

$$K_{T2} = \frac{K_{T2}}{2^{K_{T2_scale}+10} \cdot 2^{3-ConfigReg[5:4]}}$$

15.2 Example for Ta calculations

Let's assume that the values in EEPROM are as follows:

Tab. 12: examples of cell values written in the EEPROM

EEPROM address	Cell name	Cell values (hex)
0xDA	V_{TH_L}	0x78
0xDB	V_{TH_H}	0x1A
0xDC	K_{T1_L}	0x33
0xDD	K_{T1_H}	0x5B
0xDE	K_{T2_L}	0xCC
0xDF	K_{T2_H}	0xED

$$V_{TH}(25) = 256 \cdot V_{TH_H} + V_{TH_L} = 256 \cdot 26 + 120 = 6776, \text{ decimal value}$$

$$\text{Sign check } 6776 < 32767 \rightarrow V_{TH}(25) = 6776$$

$$\text{ConfigReg}[5:4] = 3 \rightarrow V_{TH}(25) = 6776$$

$$K_{T1_scale} = 10$$

$$K_{T1} = 256 \cdot K_{T1_H} + K_{T1_L} = 23347$$

$$\text{Sign check } 23347 < 32767 \rightarrow K_{T1} = 23347$$

$$K_{T1} = \frac{K_{T1}}{2^{K_{T1_scale}} \cdot 2^{3-\text{ConfigReg}[5:4]}} = \frac{23347}{1024} \approx 22.7998$$

$$K_{T2_scale} = 10$$

$$K_{T2} = 256 \cdot K_{T2_H} + K_{T2_L} = 256 \cdot 237 + 204 = 60876$$

$$\text{Sign check } 60876 > 32767 \rightarrow K_{T2} = 60876 - 65536 = -4660$$

$$K_{T2} = \frac{K_{T2}}{2^{K_{T2_scale} + 10} \cdot 2^{3-\text{ConfigReg}[5:4]}} = \frac{-4660}{1048576} \approx -0.0044441$$

Let's assume that the input data is:

$$PTAT_data = 0x1AC0 = 6848 \text{ dec}$$

Thus the ambient temperature is:

$$Ta = \frac{-K_{T1} + \sqrt{K_{T1}^2 - 4K_{T2}[V_{TH}(25) - PTAT_data]}}{2K_{T2}}$$

$$Ta \approx \frac{-22.7998 + \sqrt{519.8309 - 4(-0.0044441)[6776 - 6848]}}{-0.0088882} + 25$$

$$Ta \approx \frac{-22.7998 + \sqrt{519.8309 + 0.0177764(-72)}}{-0.0088882} + 25$$

$$Ta \approx \frac{-22.7998 + \sqrt{518.551}}{-0.0088882} + 25 \approx \frac{-22.7998 + 22.7717}{-0.0088882} + 25 \approx 3.16 + 25$$

$$Ta \approx 28.16^\circ\text{C}$$

15.3 Calculation of To

Following formula is used to calculate the temperature seen by specific pixel in the matrix:

$$T_{O(i,j)} = \sqrt[4]{V_{IR(i,j)_COMPENSATED} + (T_a + 273.15)^4} - 273.15, [^{\circ}C]$$

where:

$V_{IR(i,j)_COMPENSATED}$ is the parasitic free IR compensated signal

T_a is ambient temperature calculated in 9.4.2

15.4 Calculating VIR(I,j)_COMPENSATED

1. Offset compensation

$$V_{IR(i,j)_OFF_COMP} = V_{IR(i,j)} - (A_{i(i,j)} + B_{i(i,j)} \cdot (T_a - T_{a_0}))$$

Where:

$V_{IR(i,j)}$ is a individual pixel IR_data readout (RAM read)

$A_{i(i,j)}$ is a individual pixel offset restored from the EEPROM using the following formula:

$$A_{i(i,j)} = \frac{A_{common} + a_{i(i,j)} \cdot 2^{\Delta A_{iScale}}}{2^{3-ConfigReg[5:4]}}$$

A_{common} is the minimum offset value stored in the EEPROM at addresses 0xD0 and 0xD1 as 2's complement value

$a_{i(i,j)}$ is the difference between the individual offset and the minimum value. It is stored in the EEPROM as unsigned values.

ΔA_{iScale} is the scaling coefficient for the $a_{i(i,j)}$ values and is stored in the EEPROM at address 0xD9[7:4] as an unsigned value

$B_{i(i,j)}$ is an individual pixel offset slope coefficient

$$B_{i(i,j)} = \frac{b_{i(i,j)}}{2^{B_{iScale}} \cdot 2^{3-ConfigReg[5:4]}}$$

$b_{i(i,j)}$ is the value stored in EEPROM as two's complements

B_{iScale} is a scaling coefficient for the slopes of IR pixels offset and is stored in the EEPROM at address 0xD9[3:0] as an unsigned value

T_a is the ambient temperature calculated in 15.1

$T_{a_0} = 25^{\circ}C$ is a constant

NOTE: This applies to the compensation pixel as well (a_{CP} and b_{CP} while B_{iScale} is the same)

2. Thermal Gradient Compensation (TGC)

Heimann Sensor GmbH
 Amtsgericht Dresden
 HRB 20692
 0800 4533 00

Geschäftsführer:
 Dr. Jörg Schieferdecker
 Mischa Schulze

Steuer-Nr.: 202/110/07487
 Ust-Ident-Nr.: DE 813444739

Ostächsische Sparkasse Dresden
 SWIFT-Code: SOLADEST
 BIC: OSDDDE81XXX

IBAN: DE03 8505 0300 3120 0454 02 (EUR)
 IBAN: DE40 8505 0300 0229 0000 88 (USD)

Commerzbank AG
 BIC: COBADEFF850
 IBAN: DE77 8504 0000

$$V_{IR(i,j)_TGC_COMP} = V_{IR(i,j)_OFF_COMP} - TGC \cdot V_{IR_CP_OFF_COMP}$$

Where:

$V_{IR_CP_OFF_COMP}$ is the offset compensated IR signal of the thermal gradient compensation pixel

$$TGC = \frac{TGC_{EEPROM}}{32}$$

TGC_{EEPROM} is a coefficient stored at EEPROM address 0xD8 as a two's complement value

3. Pixel to pixel normalization

$$V_{IR(i,j)_NORMALIZED} = \frac{V_{IR(i,j)_TGC_COMP}}{\alpha_{(i,j)} - TGC \cdot \alpha_{CP}}$$

Where:

$$\alpha_{(i,j)} = \frac{256 \cdot \alpha_{0_H} + \alpha_{0_L} + \frac{\Delta\alpha_{(i,j)}}{2^{\Delta\alpha_{SCALE}}}}{2^{3-ConfigReg[5:4]}}$$

$$\alpha_{CP} = \frac{256 \cdot \alpha_{CP_H} + \alpha_{CP_L}}{2^{\alpha_{0_SCALE}} \cdot 2^{3-ConfigReg[5:4]}}$$

α_{0_H} , α_{0_L} , α_{CP_H} , α_{CP_L} , $\Delta\alpha_{(i,j)}$, α_{0_SCALE} and $\Delta\alpha_{SCALE}$ are stored in the EEPROM as unsigned values

4. Emissivity compensation

$$V_{IR(i,j)_COMPENSATED} = \frac{V_{IR(i,j)_NORMALIZED}}{\varepsilon}$$

Where:

ε is the emissivity coefficient. The scaled value is stored into EEPROM as unsigned value

$$\varepsilon = \frac{256 \cdot \varepsilon_H + \varepsilon_L}{32768}$$

Parameters necessary to calculate To are stored into EEPROM at following addresses:

Tab 13: parameter used in calculation

EEPROM address	Cell name	Stored as	Parameter
0x00...0x3F	$a_{i(i,j)}$	unsigned	IR pixel individual offset delta coefficient
0x40...0x7F	$b_{i(i,j)}$	2's complement	Individual Ta dependence (slope) of IR pixels offset
0x80...0xBF	$\Delta\alpha_{(i,j)}$	unsigned	Individual sensitivity coefficient
0xD0	A_{common_L}	2's complement	IR pixel common offset coefficient
0xD1	A_{common_H}		
0xD3	a_{CP_L}	2's complement	Compensation pixels individual offset coefficients
0xD4	a_{CP_H}		
0xD5	b_{CP}	2's complement	Individual Ta dependence (slope) of the compensation pixel offset
0xD6	α_{CP_L}	unsigned	Sensitivity coefficient of the compensation pixel
0xD7	α_{CP_H}		
0xD8	TGC	2's complement	Thermal gradient coefficient
0xD9	$\Delta A_{iScale}, B_{iScale}$	unsigned	Scaling coefficients for the IR pixels offset deltas and the slope of the IR pixels offset
0xE0	α_{0_L}	unsigned	Common sensitivity coefficient of IR pixels
0xE1	α_{0_H}		
0xE2	α_{0_SCALE}	unsigned	Scaling coefficient for common sensitivity
0xE3	$\Delta\alpha_{SCALE}$	unsigned	Scaling coefficient for individual sensitivity
0xE4	ϵ_L	unsigned	Emissivity
0xE5	ϵ_H		

15.5 Example for To calculations

Let's assume that we have following EEPROM data for pixel $i=2, j=8$:

Tab 14: example of values while calculating object temperature

EEPROM address	Cell name	Stored as	Cell values (hex)
0x22	$a_{i(2,8)}$	unsigned	0x2D
0x62	$b_{i(2,8)}$	2's complement	0xC1
0xA2	$\Delta\alpha_{(2,8)}$	unsigned	0x8F
0xD0	A_{common_L}	2's complement	0x96
0xD1	A_{common_H}		0xFF
0xD3	a_{CP_L}	2's complement	0xC8
0xD4	a_{CP_H}		0xFF
0xD5	b_{CP}	2's complement	0xCA
0xD6	α_{CP_L}	unsigned	0x80
0xD7	α_{CP_H}		0x09
0xD8	TGC	2's complement	0x18
0xD9	$\Delta A_{iScale}, B_{iScale}$	unsigned	0x07
0xE0	α_{0_L}	unsigned	0xE4
0xE1	α_{0_H}	unsigned	0xD5
0xE2	α_{0_SCALE}	unsigned	0x2A
0xE3	$\Delta\alpha_{SCALE}$	unsigned	0x21
0xE4	ε_L	unsigned	0x9A
0xE5	ε_H	unsigned	0x79

Let's assume that we have the following input data:

$$V_{CP} = 0xFFD8 = 65496, \text{ decimal value}$$

$$\text{Sign check } 65496 > 32767 \rightarrow V_{CP} = 65496 - 65536 = -40$$

$$V_{IR(2,8)} = 0x0090 = 144, \text{ decimal value}$$

$$\text{Sign check } 144 < 32767 \rightarrow V_{IR(2,8)} = 144$$

$$Ta \approx 28.16^\circ\text{C} \text{ (as calculated in 15.1)}$$

Reference routine for To computation:

$$a_{CP} = 256 \cdot a_{CP_H} + a_{CP_L} = 65480, \text{ decimal value}$$

Sign check $65480 > 32767 \rightarrow a_{CP} = 65480 - 65536 = -48$

$$A_{CP} = \frac{a_{CP}}{2^{3-ConfigReg[5:4]}} = -48$$

$b_{CP} = 0xCA = 202$, decimal value

Sign check $202 > 127 \rightarrow b_{CP} = 202 - 256 = -54$

$$B_{CP} = \frac{b_{CP}}{2^{B_{Scale}} \cdot 2^{3-ConfigReg[5:4]}} = \frac{-54}{2^7 \cdot 2^0} = -0.4219$$

$$V_{IR_CP_OFF_COMP} = V_{CP} - (A_{CP} + B_{CP} \cdot (T_a - T_{a_0})) = -40 - (-48 - 0.4219 \cdot (28.16 - 25)) \approx 9.33$$

$$A_{Common} = 256 \cdot A_{Common_H} + A_{Common_L} = 65430$$

Sign check $65430 > 32767 \rightarrow A_{Common} = 65430 - 65536 = -106$

$a_{i(2,8)} = 0x2D = 45$, decimal value

$$A_{i(2,8)} = \frac{A_{Common} + a_{i(2,8)} \cdot 2^{\Delta A_{Scale}}}{2^{3-ConfigReg[5:4]}} = \frac{-106 + 45 \cdot 2^0}{2^0} = -61$$

$b_{i(2,8)} = 0xC1 = 193$, decimal value

Sign check $193 > 127 \rightarrow b_{i(2,8)} = 193 - 256 = -63$

$$B_{i(2,8)} = \frac{b_{i(2,8)}}{2^{B_{Scale}} \cdot 2^{3-ConfigReg[5:4]}} = \frac{-63}{2^7 \cdot 2^0} = -0.4922$$

$$V_{IR(2,8)_OFF_COMP} = V_{IR(2,8)} - (A_{i(2,8)} + B_{i(2,8)} \cdot (T_a - T_{a_0})) = 144 - (-61 - 0.4922 \cdot (28.16 - 25)) \approx 81.44$$

$TGC_{EEPROM} = 0x18 = 24$, decimal value

Sign check $24 < 127 \rightarrow TGC_{EEPROM} = 24$

$$TGC = \frac{TGC_{EEPROM}}{32} = \frac{24}{32} = 0.75$$

$$V_{IR(i,j)_TGC_COMP} = V_{IR(i,j)_OFF_COMP} - TGC \cdot V_{IR_CP_OFF_COMP} = 81.44 - 0.75 \cdot 9.33 \approx 74.44$$

$$\alpha_{(2,8)} = \frac{256 \cdot \alpha_{0_H} + \alpha_{0_L} + \frac{\Delta \alpha_{(2,8)}}{2^{\Delta \alpha_{SCALE}}}}{2^{\alpha_{0_SCALE}} \cdot 2^{3-ConfigReg[5:4]}} = \frac{256 \cdot 213 + 228}{2^{42}} + \frac{143}{2^{33}} \approx 2.9097 \cdot 10^{-8}$$

$$\alpha_{CP} = \frac{256 \cdot \alpha_{CP_H} + \alpha_{CP_L}}{2^{\alpha_{0_SCALE}} \cdot 2^{3-ConfigReg[5:4]}} = \frac{2432}{2^{42} \cdot 2^0} = 5.5297 \cdot 10^{-10}$$

$$V_{IR(2,8)_NORMALIZED} = \frac{V_{IR(2,8)_TGC_COMP}}{\alpha_{(2,8)} - TGC \cdot \alpha_{CP}} = \frac{74.44}{2.9097 \cdot 10^{-8} - 0.75 \cdot 5.5297 \cdot 10^{-10}} = 2522387075$$

$$\varepsilon = \frac{256 \cdot \varepsilon_H + \varepsilon_L}{32768} = \frac{256 \cdot 121 + 154}{32768} = \frac{31130}{32768} \approx 0.95$$

$$V_{IR(2,8)_COMPENSATED} = \frac{V_{IR(2,8)_NORMALIZED}}{\varepsilon} = \frac{2522387075}{0.95} \approx 2655144289$$

$$T_{O(2,8)} = \sqrt[4]{V_{IR(2,8)_COMPENSATED} + (T_a + 273.15)^4} - 273.15$$

$$T_{O(2,8)} = \sqrt[4]{2655144289 + (28.16 + 273.15)^4} - 273.15 \approx 49.95^\circ\text{C}$$

16 Performance Graphs

16.1 Temperature accuracy

All accuracy specifications apply under settled isothermal conditions only. Furthermore, the accuracy is only valid if the object fills the FOV of the sensor completely.

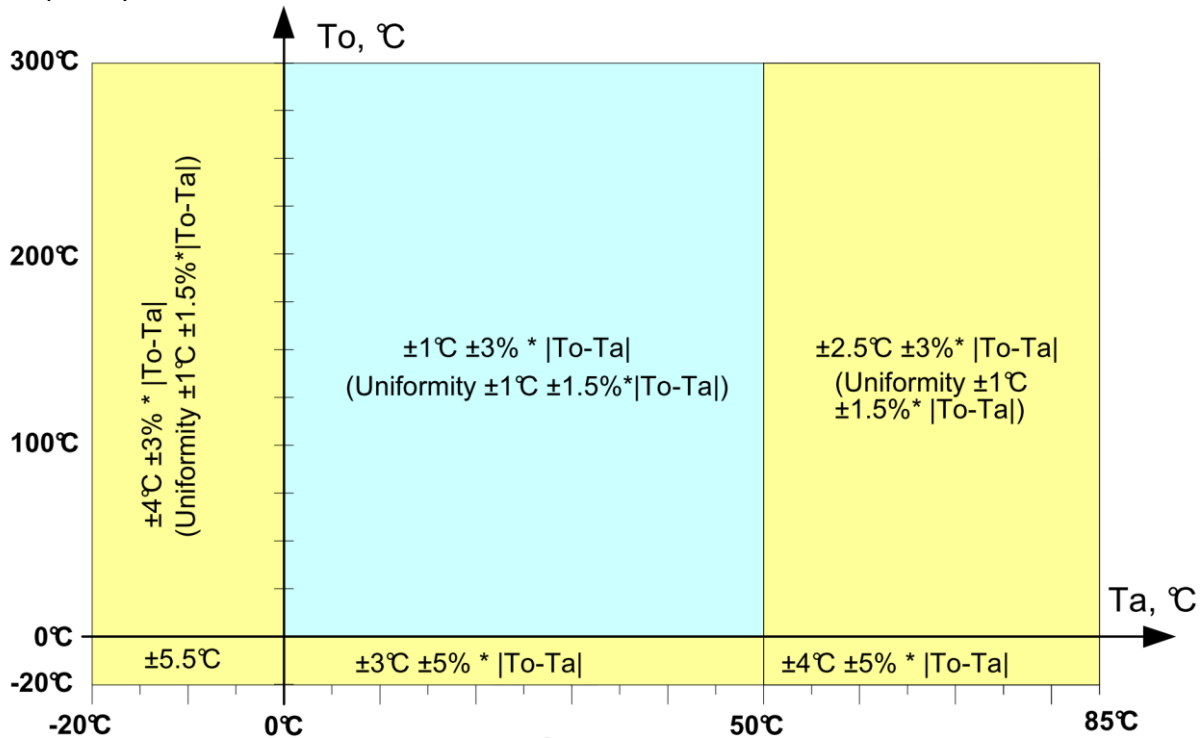

Figure 23: Absolute temperature accuracy for the central four pixels

NOTE: The accuracy is specified for the four central pixels. The accuracy of the rest of the pixels is according to the uniformity statement

16.2 Noise performance and resolution

There are two bits in the configuration register that allow changing the resolution of the HTPA16x4R1 measurements. Increasing the resolution decreases the quantization noise and improves the overall noise performance.

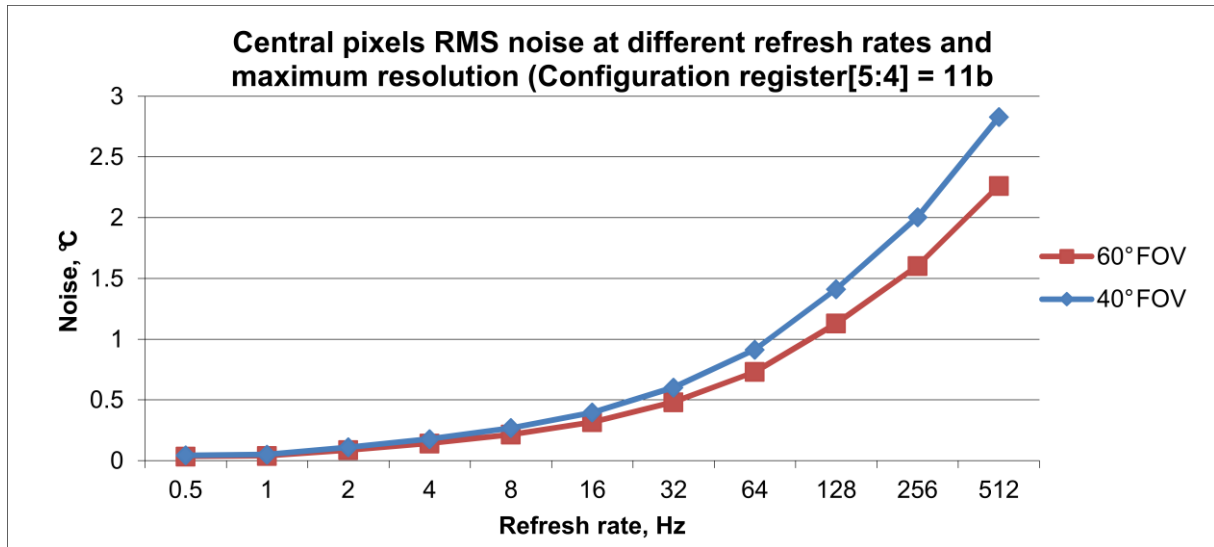

Figure 24: Central pixels noise

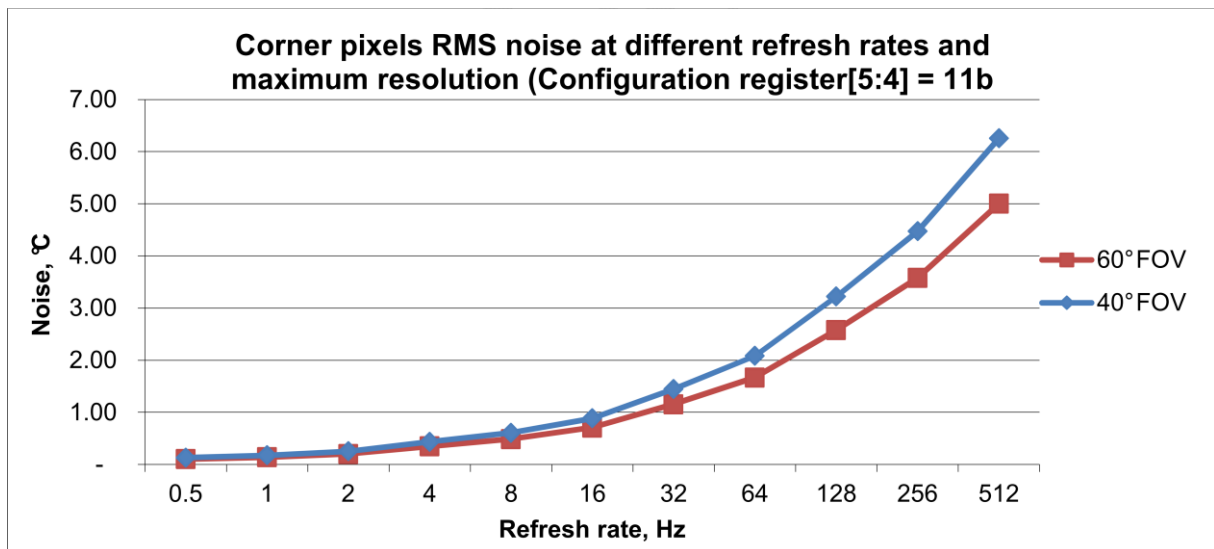

Figure 25: Corner pixels noise

A higher resolution limits the maximum object temperature range of the HTPA16x4R1.

Tab 15: Maximum object temperature at different resolution settings

Configuration register [5,4], bin	Resolution	Maximum object temperature in °C
00	15 bits	~1100
01	16 bits	~900
10	17 bits	~700
11	18 bits	~500

NOTE: If the object temperature exceeds the maximum object temperature specified for the corresponding resolution, the HTPA16x4R1 may return invalid data due to measurements overflow.

16.3 Calculated Field Of View (FOV)

The FOV must be separated in this case in two directions, because the HTPA 16x4 has 16 sensors in the width and 4 in the height.

Tab. 16: calculated field of view (FOV)

parameter			unit
	16 sensors	4 sensors	
Field of View L7.0	28.22	7.19	degree
Field of View L5.5EA	35.49	9.15	degree
Field of View L3.6EA	52.11	13.94	degree
Field of View L2.85	63.39	17.55	degree
Field of view L2.1	90	23.7	degree

17 Applications Information

17.1 Use of the HTPA 16x4 in I²C configuration

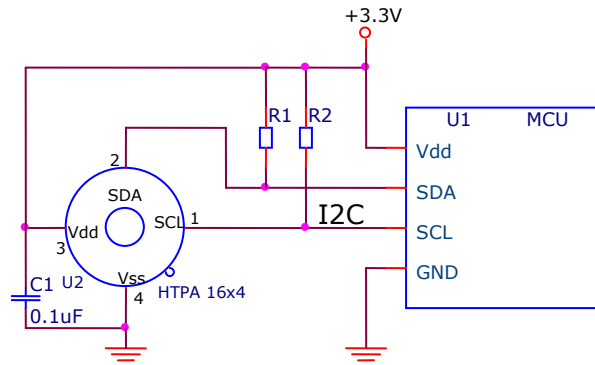

Figure 26: wire connection I²C

Figure 26 shows the connection of a HTPA 16x4 to an I²C with 3.3V power supply. The HTPA 16x4 has diode clamps SDA/SCL to Vdd so it is necessary to provide HTPA 16x4 with power in order not to load the I²C lines.

18 Application Comments

Significant **contamination** at the optical input side (sensor filter) might cause unknown additional filtering/distortion of the optical signal and therefore result in unspecified errors.

IR sensors are inherently susceptible to errors caused by **thermal gradients** from the front lens to the sensor die. This phenomenon is called "**heat shock**". When the front cap or lens emits more heat than the sensor die, the sensor receives more heat than it can compensate itself from its own ambient heat. Therefore the sensor is "shielded" and is not able to measure in specified ranges. In spite of the careful design of the HTPA 16x4 it is recommended not to subject the HTPA 16x4 to heat transfer and especially transient conditions. Front cap, front lens and sensor die should have the same ambient temperature.

The HTPA 16x4 is designed and calibrated to operate as a non contact thermometer in settled conditions. Using the thermometer in a very different way will lead to unknown results.

Capacitive loading on a I²C can degrade the communication. Some improvement is possible with use of current sources compared to resistors in pull-up circuitry. Further improvement is possible with specialized commercially available bus accelerators. With the HTPA 16x4 additional improvement is possible by increasing the pull-up current (decreasing the pull-up resistor values). Input levels for I²C compatible mode have higher overall tolerance than the I²C specification, but the output low level is rather low even with the high-power I²C specification for pull-up currents. Another option might be to go for a slower communication (clock speed), as the HTPA 16x4 implements Schmidt triggers on its inputs in I²C compatible mode and is therefore not really sensitive to rise time of the bus (it is more likely the rise time to be an issue than the fall time, as far as the I²C systems are open drain with pull-up).

Power dissipation within the package may affect performance in two ways: by heating the "ambient" sensitive element significantly beyond the actual ambient temperature, as well as by causing gradients over the package that will inherently cause thermal gradient over the cap.

Power supply decoupling capacitor is needed as with most integrated circuits. HTPA 16x4 is a mixed-signal device with sensors, small signal analog part, digital part and I/O circuitry. In order to keep the noise low power supply switching noise needs to be decoupled. High noise from external circuitry can also affect noise performance of the device. In many applications a 100nF SMD ceramic capacitor close to the Vdd and Vss pins would be a good choice. It should be noted that not only the trace to the Vdd pin needs to be short, but also the one to the Vss pin. Using HTPA 16x4 with short pins improves the effect of the power supply decoupling.

19 Initialization

After POR is released the chip executes an initialization procedure, this procedure starts typ. 16ms after POR release and requires only a few ms. In that time the device will read its configuration from the reserved part of the EEPROM and will load it in the registers of the HTPA16x4. The settings that are loaded are:

- Oscillator trimming data
- Bias trimming data
- Regulator control
- ConfReg settings

During that time the HTPA16x4 will work as Master I²C device for the EEPROM chip. Note that this will not affect the external I²C bus, i.e. the information transmitted between HTPA16x4 and EEPROM chip will not be visible externally.

During the initialization, the HTPA16x4 will block any access through external I2C line and will not respond to any commands. This means that a NoACKN will be received by the external MCU if the HTPA16x4 or EEPROM chip is addressed.

20 Liability

The contents of this document are subject to change without notice.

Changes or modifications at the product which haven't influence to the performance and/or quality of the device haven't to be announced to the customers in advance.

Customers are requested to consult with Heimann Sensor representatives before the use of Heimann Sensor products in special applications where failure or abnormal operation may directly affect human lives or cause physical injury or property damage. The company or their representatives will not be responsible for damage arising from such use without prior approval.

21 Glossar

ADC	A nalog to D igital C onverter
DSP	D igital S ignal P rocessing
EMC	E lectro- M agnetic C ompatibility
ESD	E lectro- S tatic D ischarge
FOV	F ield O f V iew
FpS	F rames p er S econd (data refresh rate)
HFO	H igh F requency O scillator (RC type)
I ² C	I nter- I ntegrated C ircuit communication protocol
IR	I nfra R ed
IR_data	I nfra R ed data (raw data from ADC proportional to IR energy received from the sensor)
MD	M aster D evice
NA	N ot A pplicable
POR	P ower O n R eset
PTAT	P roportional T o A bsolute T emperature sensor (package temperature)
SCL	S erial C lock
SD	S lave D evice
SDA	S erial D ata
Ta	A mbient T emperature
TGC	T emperature G radient C oefficient
TBD	T o B e D efined
To	O bject T emperature, 'seen' from IR sensor